

From Full Replacement to Targeted Rehab: How Acquaint's Tech Transformed a Force Main Plant

Edzer Kooistra



January 27 – 28, 2026

Henry B. Gonzalez Convention Center, San Antonio, Texas



SYSTEM AT A TURNING POINT

- ~888 miles gravity sewer mains
- ~50 miles force mains
- Rapid expansion post-WWII
- Assets now reaching design life

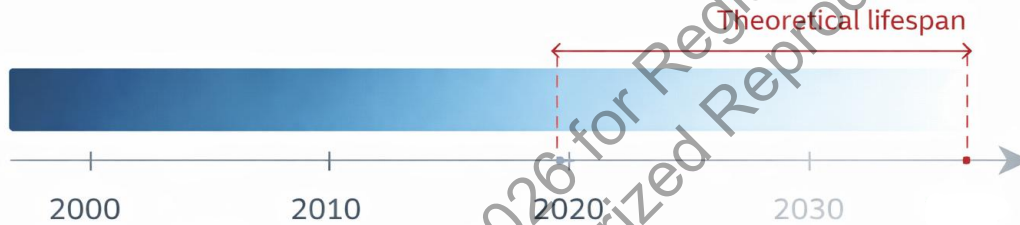

CHALLENGE WITH 24" DI FM

- Failure near waterway crossing
- History of earlier incidents
- Triggered involvement of consultants
- Full replacement considered



Size & Material:	24" DIP
Approx. Length:	18,920 LF
Linings/Coatings:	Polyethylene encasement; lining unknown
Valves:	24" plug valve just outside of LS
Pig Launching Station:	Launching station at LS63 (12" or smaller)
Drawings Provided:	- 1980 FM Original Construction - 1988 LS Original Construction
Other Background Docs:	- 1998 Lift Station Survey - 2017 Carollo LS63 Rehab Preliminary Evaluations Report - 2001 NEWRF Headworks - GIS Shapefiles



RECONSIDERED THE FULL REPLACEMENT

- Avoid full replacement unless absolutely necessary
- Assess structural integrity and remaining useful life
- Identify locations of significant deterioration
- Develop a proactive maintenance and rehabilitation plan
- Highest possible resolution required

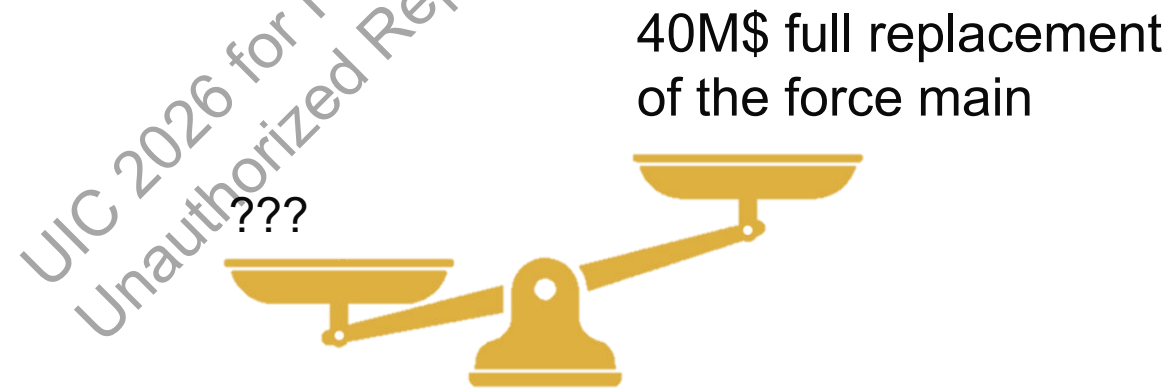

January 27 – 28, 2026

Henry B. Gonzalez Convention Center, San Antonio, Texas



SELECTING THE INSPECTION TOOL

UT PIG

- ✓ Absolute condition assessment data
- ✓ Dual layer capability
- ✓ High resolution
- ! Relatively unknown in US

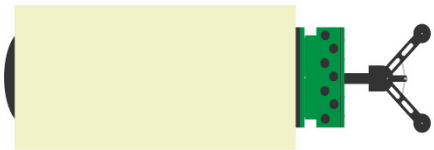

EM Tool

- ! Relative metal measurements
- ✓ More experienced in US
- ✓ Little less expensive than UT Tool

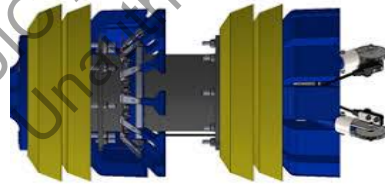

INSPECTION BALL

- ! Only leak detection and XY mapping
- ✓ Easy to insert
- ✗ Cheaper but delivers way less data



CCTV

- ✗ Force main needs to be shut down for long period of time
- ✗ Doesn't really give condition data



EM vs UT IN CEMENT LINED DUCTILE IRON

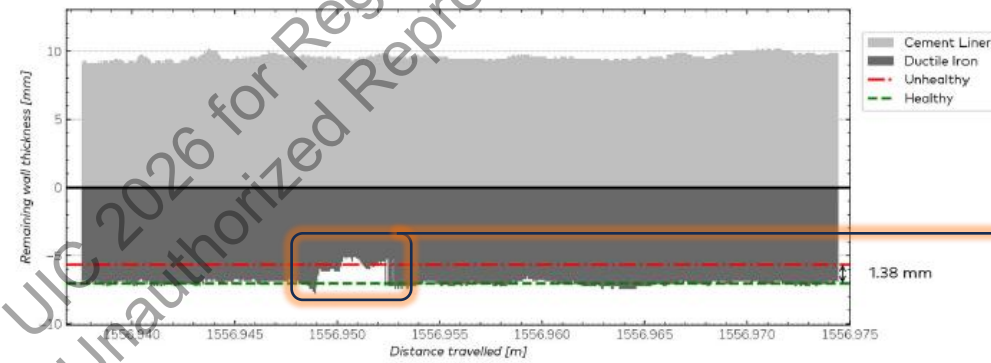
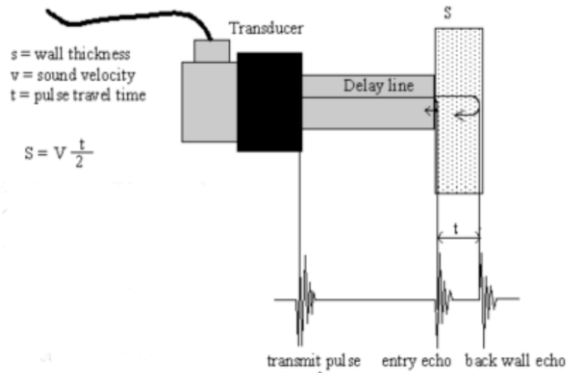
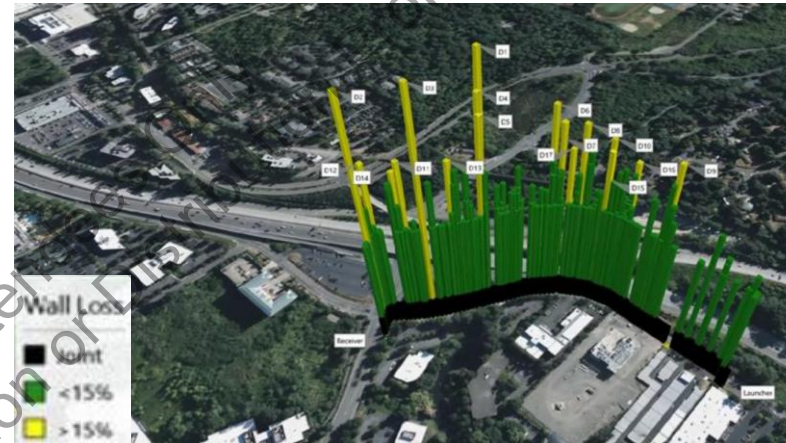
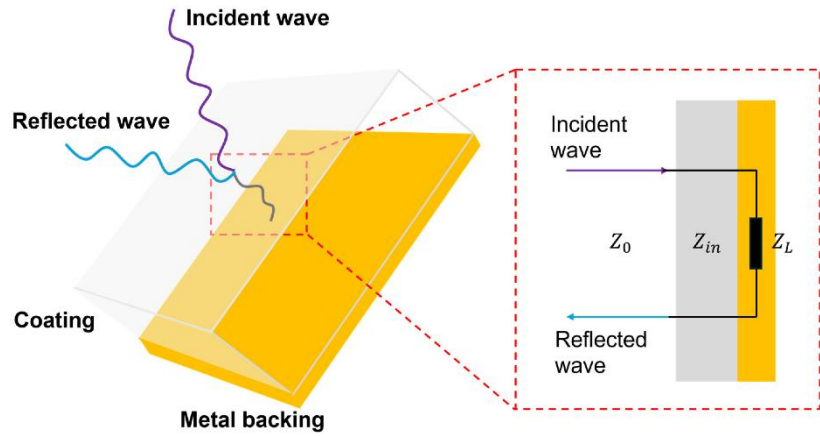

Figure 25: Remaining wall thickness around damaged outside wall



January 27 – 28, 2026

Henry B. Gonzalez Convention Center, San Antonio, Texas



UT PIG (Acquarius) experience in the US

Grapevine



2022
Acquarius
PCCP
4,462 ft
20" diameter
Raw water

Oklahoma City



2023
Acquarius
Cast Iron
10,532 ft
10" diameter
Waste water

St Pete



2023
Acquarius
Ductile Iron – Cement Lined
18,917ft
26" diameter
Waste water

Cobb County



2024
Acquarius
Ductile Iron – Cement Lined
9,678 ft
20" diameter
Waste water

Marshfield



2025
Acquarius
DICT
3,000 ft
20" diameter
Waste water

Muskogee



2025
Acquarius
Concrete
36,000 ft
48" diameter
Raw water main

January 27 – 28, 2026

Henry B. Gonzalez Convention Center, San Antonio, Texas



SPECS ACQUARIUS

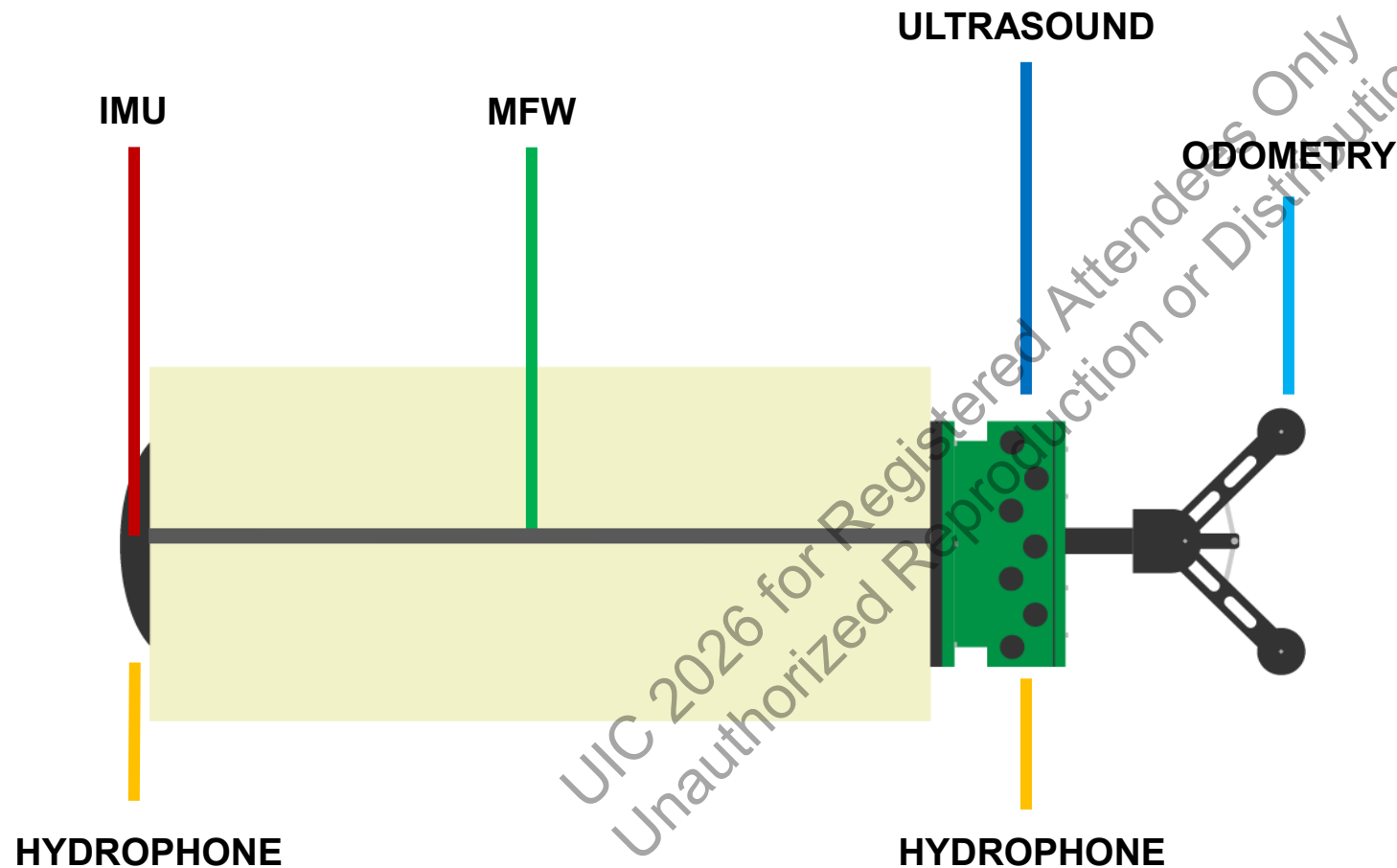

- Many miles in a single run
- Drinking water and sewage
- Non-destructive
- Diameter > 10"
- Diameter reductions & 90° bends
- Proven technology in more than **210** projects worldwide

January 27 – 28, 2026

Henry B. Gonzalez Convention Center, San Antonio, Texas



Measurements Acquarius	Steel/DI/Ci	Concrete	AG	Plastics (PE/PVC/GRP)
XYZ Mapping (1.6 ft)	✓	✓	✓	✓
Wall Thickness (0.019 inch)	✓ (corrosion)	✓	✓ (leaching)	✓ (delamination)
Joint Angular displacement (0,25°)	✓	✓	✓	✓
Joint Gap Width (0.16 inch)	x (or condition welds)	✓	✓	✓
Ovality (0,5%-point)	✓	✓	✓	✓
Axial Deformation (7.8 inch)	✓	✓	✓	✓
Leaks (>13.0 dB)	✓	✓	✓	✓
Air pockets	✓	✓	✓	✓
Debris	✓	✓	✓	✓
Wire break		✓ (C301/303)		



ACQUARIUS USA-PARTNER LANDSCAPE

CPM – selected as delivery partner for this project
Bringing international innovations to the U.S. market
BulletLiner | Pipers | Acquarius

Other Acquaint U.S. partners:

SFE Global – pigging

APS – pigging

RedZone – CCTV gravity mains



UIC 2026 for Registered Attendees Only
Unauthorized Reproduction or Distribution Prohibited



THE PROJECT

2024		22/6	24/6	25/6	26/6	27/6	28/6	29/6
#	Steps	Sat	Mon	Tue	Wed	Thu	Fri	Sat
1	Preparation	←						
2	Mobilization							
3	Set out Marker locations							
4	2x Cleaning & check cleanliness							
5	Dummy pig @119.000 Gallons/hour (450 m³/h)							
6	Re-measure markers							
7	Prep Inspection							
8	Inspection run @119.000 Gallons/hour (450 m³/h)							
9	Upload & Check data							
10	Demobilization							
11	Site report							
12	Final report ILI							→
	Acquaint							
	CPM							



January 27 – 28, 2026

Henry B. Gonzalez Convention Center, San Antonio, Texas



(1/3) PIGGING PROCEDURE

1: CLEANING RUNS



PURPOSE

Remove sediment, residues and other dirt. For high quality data a clean pipe wall is required.
Test pipe on obstacles.

CHARACTERISTICS

- ✓ Extremely flexible soft foam PIG*.
- ✓ 1.3 – 1,9 ft/s
- ✓ Trackable
- ✓ Pressure monitoring at launch site



(2/3) PIGGING PROCEDURE

2: DUMMY RUNS



PURPOSE

Test pipeline on free passage and smooth run without damaging the dummy sensor head. Location markers placed during PIG-tracking.

CHARACTERISTICS

- ✓ Medium density foam PIG
- ✓ Dummy sensor head
- ✓ 1.3 ft/s
- ✓ Trackable
- ✓ Pressure monitoring at launch site



(3/3) PIGGING PROCEDURE

3: INSPECTION RUNS

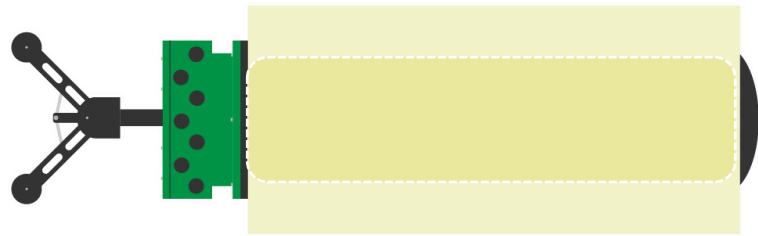

PURPOSE

Collection of pipe integrity and XYZ-data.

A clean pipeline and steady flow ensure the highest quality sensor data.

CHARACTERISTICS

- ✓ Medium density foam PIG
- ✓ Acquarius sensors
- ✓ 1.3 ft/s
- ✓ Trackable
- ✓ Pressure monitoring at launch site



LAUNCH SET UP

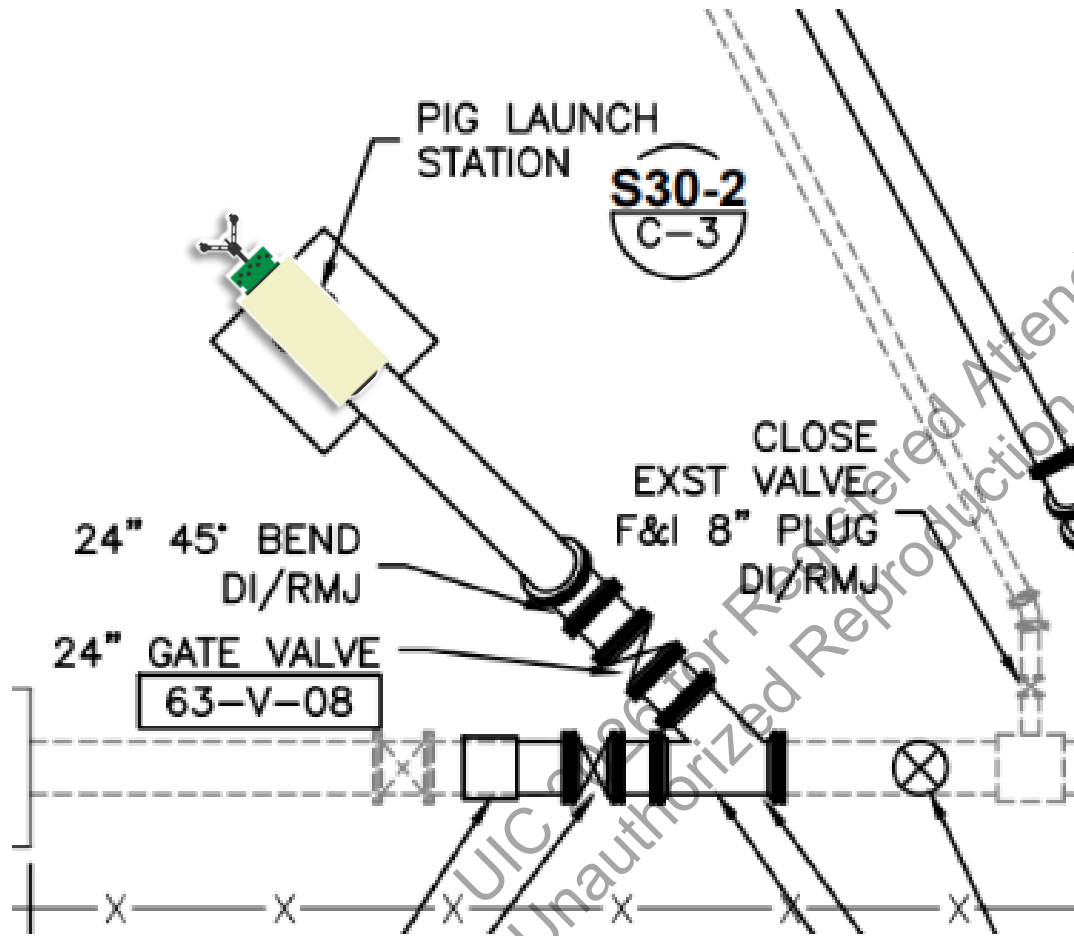

January 27 – 28, 2026

Henry B. Gonzalez Convention Center, San Antonio, Texas



LAUNCHING ILI INSPECTION TOOL

1. Place PIG in launch tower, push to tight fit
2. Close lid and start external pump
3. Force PIG into main pipeline
4. Stop external pump and switch to system pump (optional)

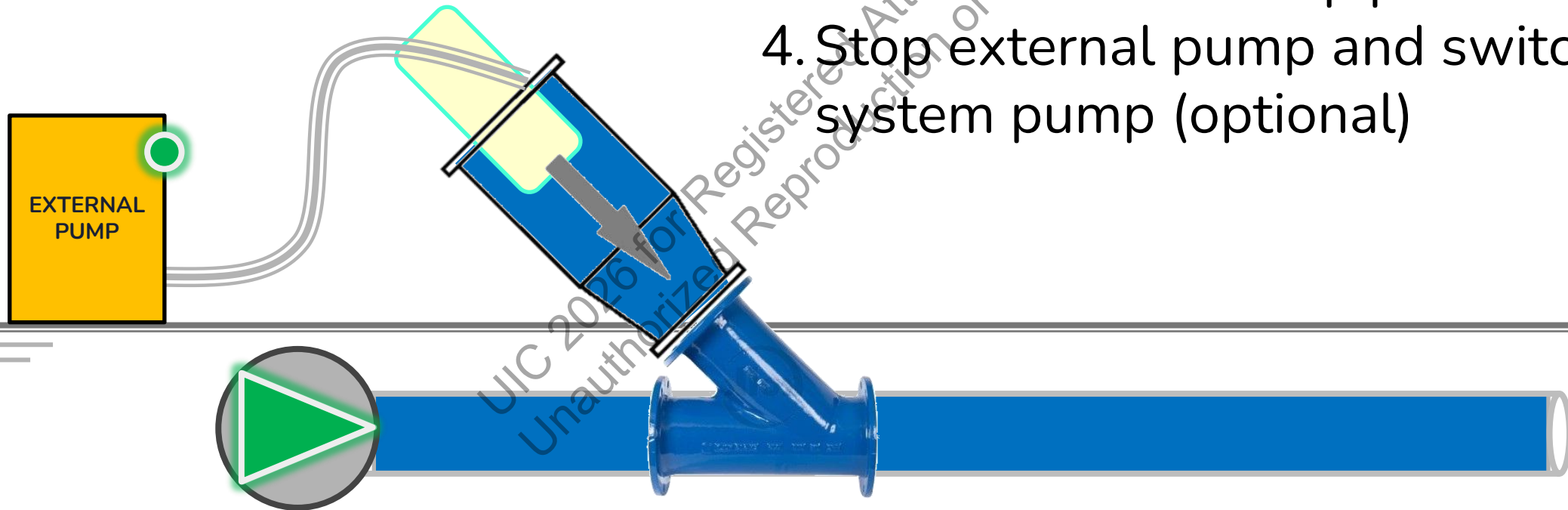

January 27 – 28, 2026

Henry B. Gonzalez Convention Center, San Antonio, Texas



TRACKING PROCEDURE

Real-time flow and pressure monitoring at start of pipe trajectory

Live tracking of PIG/ACQUARIUS

Clacking the speed of PIG/ACQUARIUS

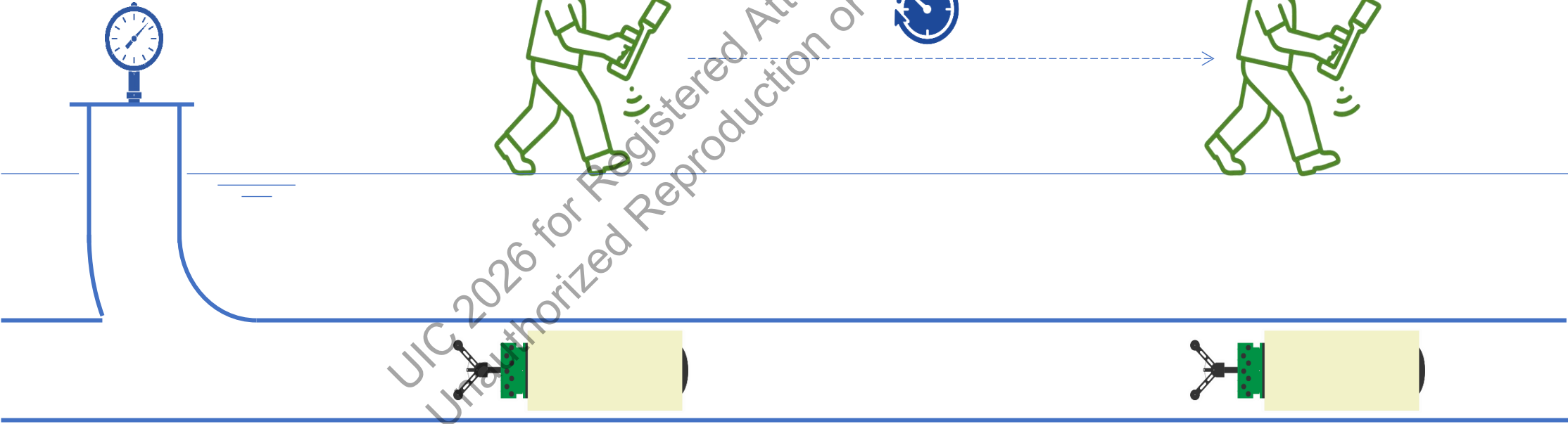

UIC 2026 for Registered Attendees Only
Unauthorized Reproduction or Distribution Prohibited



RETRIEVAL SET UP

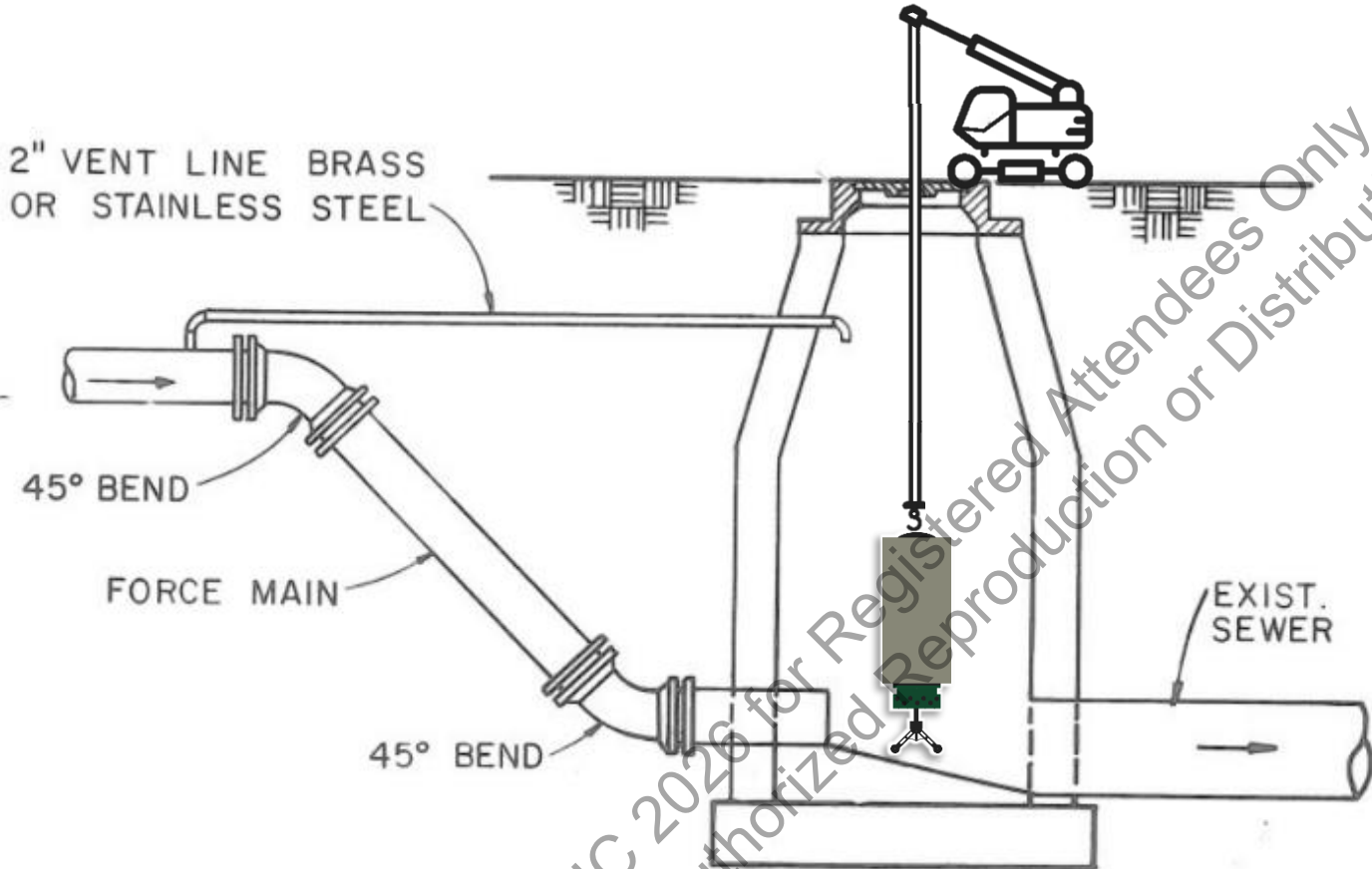

January 27 – 28, 2026

Henry B. Gonzalez Convention Center, San Antonio, Texas



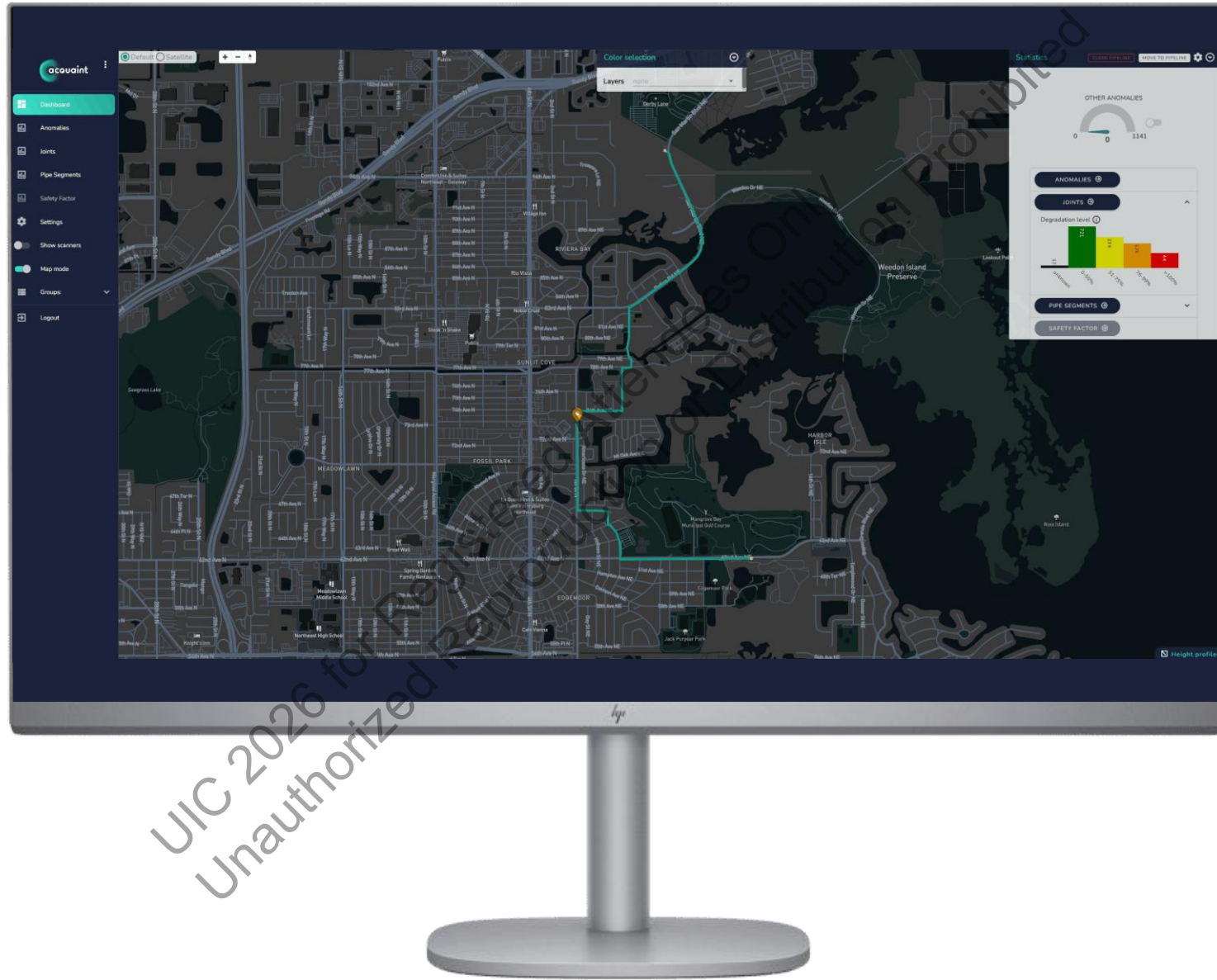

UIC 2026 for PROHIBITED
Unauthorized Presentation

January 27 – 28, 2026
Henry B. Gonzalez Convention Center, San Antonio, Texas



(1/2) RESULTS

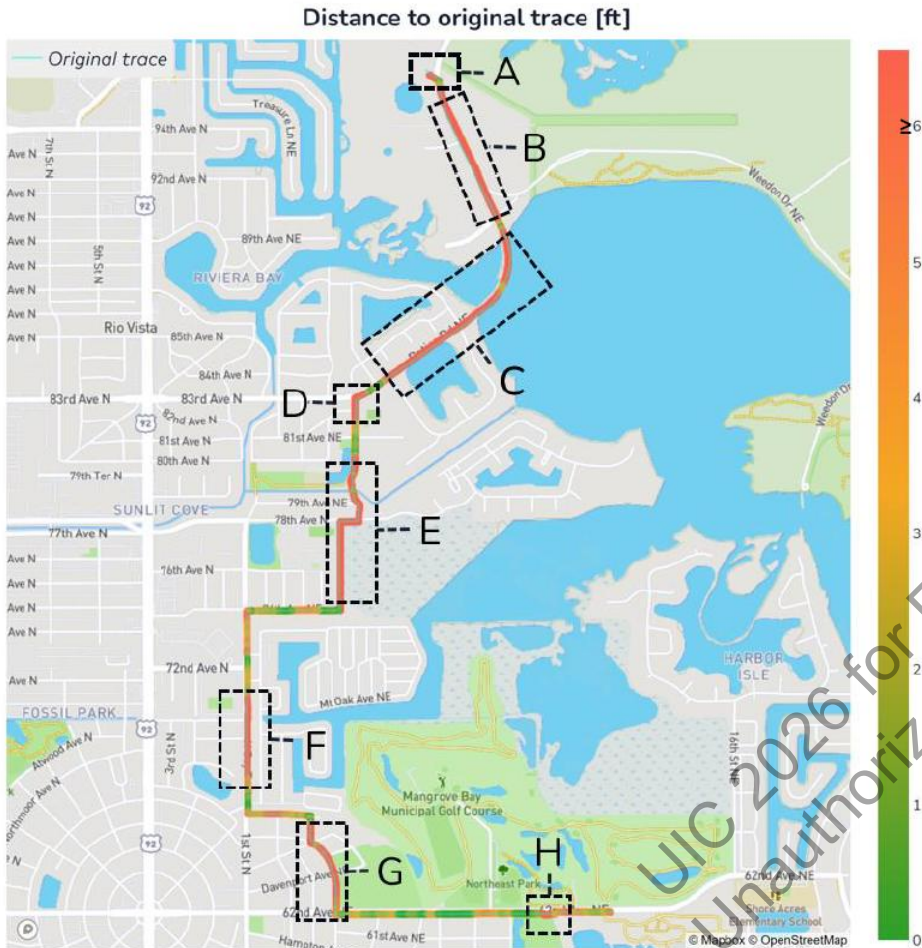

Sewage Force Main 1980;
24" ductile iron pipe;
18,900 ft
40,000,000 \$ budget reserved for replacement

XYZ location corrected

Unknown material identified

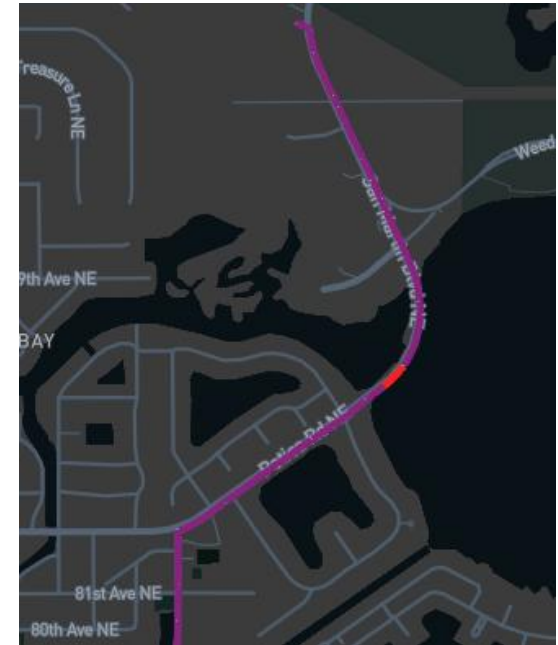

January 27 – 28, 2026

Henry B. Gonzalez Convention Center, San Antonio, Texas



(2/2) RESULTS

- Validation of wall thickness measurement
- Investigation on unknown material
- 40M\$ investment put on hold

- ✓ Gas pockets identified
- ✓ Stable wall thickness showing little to no

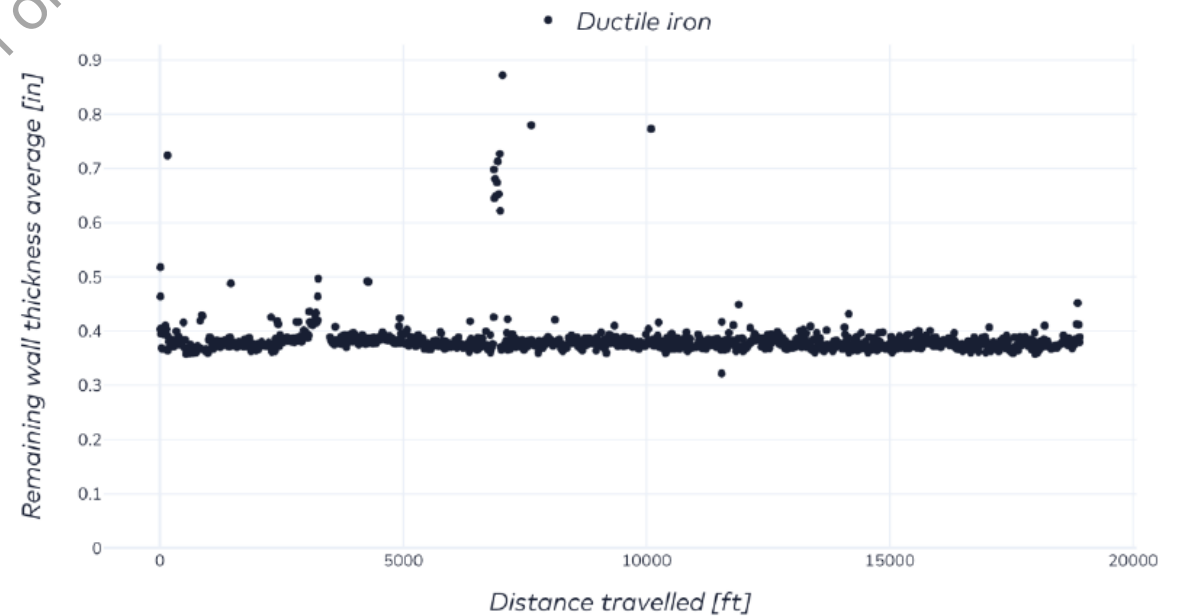
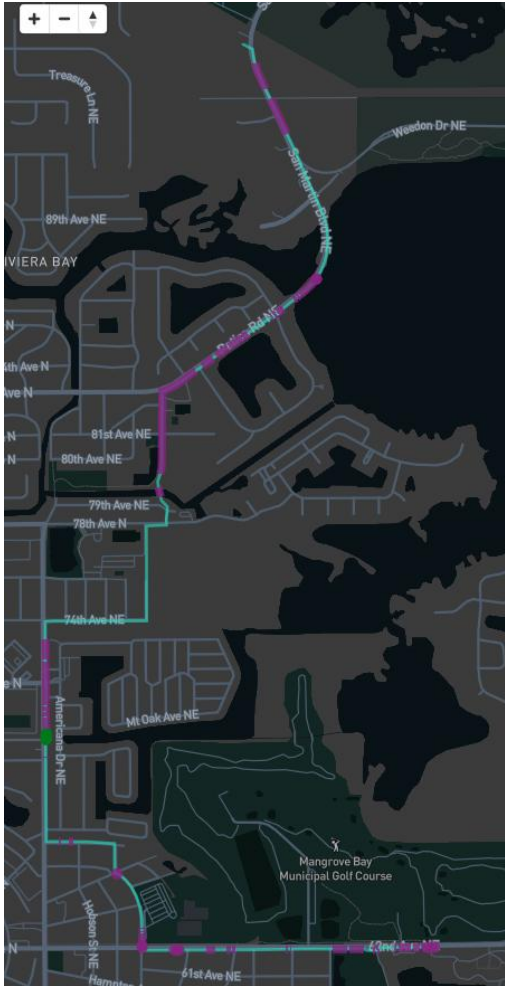

January 27 – 28, 2026

Henry B. Gonzalez Convention Center, San Antonio, Texas



(1/2) FIELD VALIDATION



Date: October 15, 2025

Subject: LS 63 FM Electromagnetic Assessment Tool Pipe Wall Thickness Verification at Pits 1 & 6

- Two excavations on 24-in ductile iron force main
- External UT as benchmark (Olympus 38DL Plus)
- EM supporting screening method
- Verification at locations with limited inline UT due to trapped gas

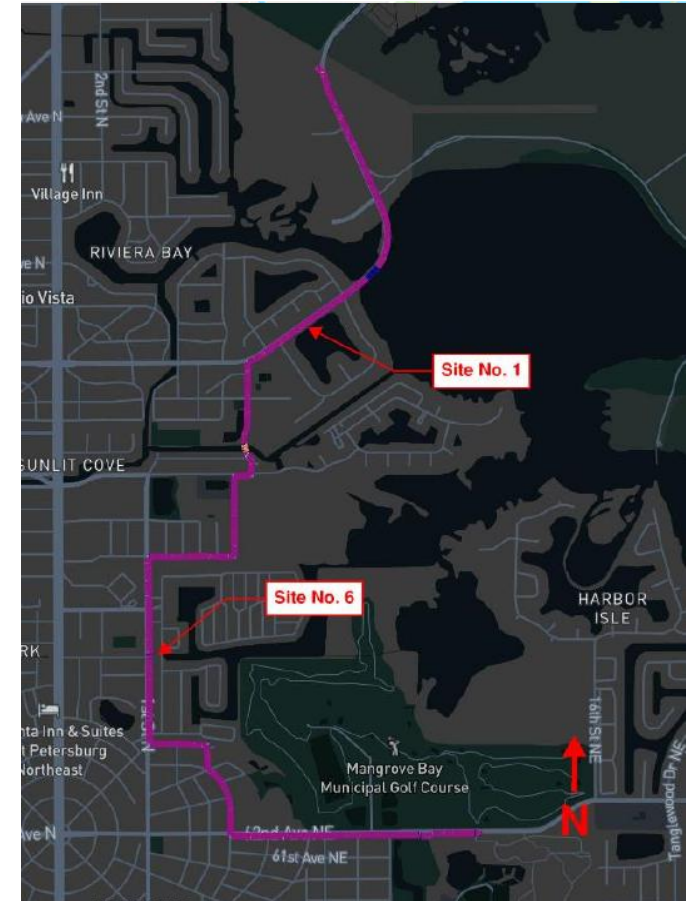

January 27 – 28, 2026

Henry B. Gonzalez Convention Center, San Antonio, Texas



(2/2) FIELD VALIDATION



- Strong alignment between field UT & Acquarius inline UT
- Wall-loss patterns matched at both pits
- No change in factor of safety required by City



Location	UT avg [in]	Acquarius avg	Deviation
Pit 1	~0.42	~0.41–0.43	Low
Pit 6	~0.36	~0.35–0.37	Low



COST COMPARISON

40M\$ full replacement of the force main

500K\$ total investment



Saving the city **39.5M\$!!**



NEXT STEPS FOR THE CITY

- No full rehab required
- Limited spot repairs only
- Re-inspection considered in ~10–15 years

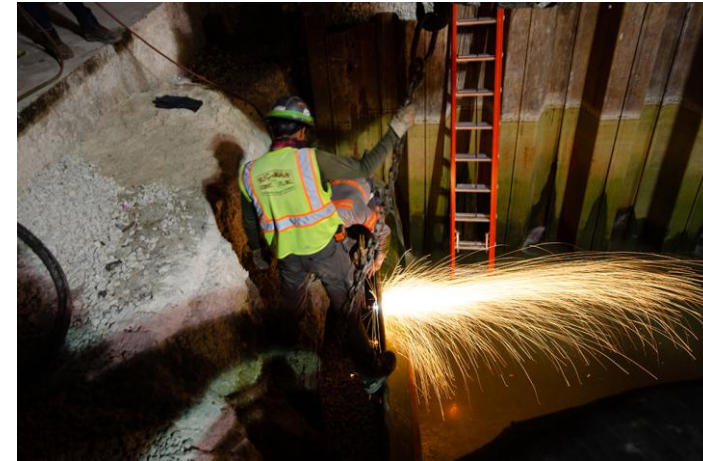

January 27 – 28, 2026

Henry B. Gonzalez Convention Center, San Antonio, Texas



THE STORY OF WL

- Aging AC force main network totaling roughly 111 miles
 - Estimated replacement value around **\$1.25B**
 - Majority installed in the 70s-80s with assumed service lives of 50–65 years
-
- Utility, consultant, contractor, and ACQUARIUS brought together for a large-scale assessment
 - 85 miles across 34 force mains selected for inspection, based on strong earlier ACQUARIUS results
 - Total inspection scope estimated at **~\$6M... under 8%** of the replacement cost for these assets

January 27 – 28, 2026

Henry B. Gonzalez Convention Center, San Antonio, Texas



THEORETICAL APPROACH RISK INVENTORY

Name	Code	Installation Year	Length (ft)	Material (converted)	Diameter (in)	Age (yrs)	Water Quality	Gas Inclusion Possible	Gas Supply	Probability of Failure	Probability of Leakage	Risk Priority Number
Strijthagen – WWTP Hoensbroek	7757	1973	4,265	AC, PVC, PCCP	19.7	52	Poor	Yes	High	10	10	22,560
Haandrade – Eygelshoven	7953	1973	1,969	AC, PCP	19.7	52	Poor	Yes	High	10	10	22,560
Oostrum – WWTP Venray	3354	1974	4,921	AC, PCP, HDPE, GRP	23.6	51	Poor	Yes	High	10	10	21,620
Belfeld – Tegelen	2762	1978	8,530	PCP	31.5	47	Poor	Yes	High	10	10	18,060
Oost-Maarland – WWTP Heugem	6112	1980	4,593	PCP, GRP	22.8	45	Poor	Yes	High	10	10	16,400
Gronsveld – WWTP Heugem	6115	1980	1,969	AC	11.8	45	Poor	Yes	High	10	10	16,400
Willem Alex.weg – WWTP Limmel	5754	1973	1,969	AC, GRP	19.7	52	Poor	Yes	Low	7	7	15,792
Castenray – Oostrum	3320	1981	9,514	AC, PVC, GRP, Steel	63.0	44	Poor	Yes	High	10	10	15,600
Nunhem – Haelen	7303	1981	3,937	AC	9.8	44	Poor	Yes	High	10	10	15,600
Haelen – Buggenum	7343	1981	3,937	AC	11.8	44	Poor	Yes	High	10	10	15,600
Helden – Maasbree WWTP Venlo	2709	1982	22,966	AC, GRP	23.6	43	Poor	Yes	High	10	10	14,820
Maasbree – WWTP Venlo	2711	1982	18,373	AC, Steel, GRP, PVC (A73)	23.6	43	Poor	Yes	High	10	10	14,820
Kessel – Baarlo	2714	1982	21,982	AC, GRP	15.7	43	Poor	Yes	High	10	10	14,820
Baarlo – Blerick	2716	1982	18,701	AC, PVC	19.7	43	Poor	Yes	High	10	10	14,820
Meers – Stein	6906	1983	4,593	AC	7.9	42	Poor	Yes	High	10	10	14,060
Montfort – Linne	7305	1984	8,858	AC	15.7	41	Poor	Yes	High	10	10	13,320
Linne – Roermond	7310	1984	18,701	AC, PCP, GRP	27.6	41	Poor	Yes	High	10	10	13,320
Neer – Buggenum	7326	1984	3,937	AC	11.8	41	Poor	Yes	High	10	10	13,320
Baaxem – Heythuysen	7331	1984	5,249	AC, HDPE	11.8	41	Poor	Yes	High	10	10	13,320
Herten – Roggel	7335	1984	18,045	AC, PVC, PCP	7.9	41	Poor	Yes	High	10	10	13,320
Roggel – Neer	7337	1984	11,155	AC, PE	27.6	41	Poor	Yes	High	10	10	13,320
Roosteren – Illikhoven	6530	1985	10,827	AC, PVC	9.8	40	Poor	Yes	High	10	10	12,600
Heythuysen – Roggel	7333	1985	11,483	AC, GRP	23.6	40	Poor	Yes	High	10	10	12,600
Wehl – Meelo	3307	1986	12,139	AC, HDPE, GRP	11.8	40	Poor	Yes	High	10	10	11,900
Wellerlooi – Blitterswijk	3309	1986	5,577	AC, HDPE	7.9	40	Poor	Yes	High	10	10	11,900
Herten – WWTP Panheel	6718	1986	21,654	AC	19.7	40	Poor	Yes	High	10	10	11,900
Urmond – WWTP Stein	6904	1986	8,202	AC, HDPE	7.9	40	Poor	Yes	High	10	10	11,900
Vlodrop – Roermond	7385	1986	24,278	AC	11.8	40	Poor	Yes	High	10	10	11,900
Swalmen – Roermond	7319	1986	10,171	AC	13.8	40	Poor	Yes	High	10	10	11,900
Nederweert – WWTP Weert	4762	1980	8,530	AC	19.7	45	Poor	Yes	Low	7	7	11,480
Nuth – WWTP Hoensbroek	5152	1973	3,609	AC, GRP	15.7	52	Good	Yes	High	5	9	11,468
Swolgen – Meerlo	3315	1987	12,467	AC, HDPE, PVC	13.8	38	Poor	Yes	High	10	10	11,220
Bunde – Meerssen	5708	1987	5,249	AC, PCP, GRP, Steel	17.7	38	Poor	Yes	High	10	10	11,220
Eygelshoven – WWTP Rimborg	7955	1973	1,640	AC, PCP	19.7	52	Poor	No	Low	5	2	11,139
			63.1 miles									

January 27 – 28, 2026

Henry B. Gonzalez Convention Center, San Antonio, Texas



DATA INTERPRETATION

- Acquarius data delivered via the dashboard
- All inspected force mains visualized in one clear overview
- Consultant applied remaining life calculations using inspection data
- Benchmarked against theoretical lifetime assumptions... setting the stage for new insights

UIC 2026 for Registered Attendees Only
Unauthorized Reproduction or Distribution Prohibited



January 27 – 28, 2026

Henry B. Gonzalez Convention Center, San Antonio, Texas



LARGE SCALE TARGETED REHAB

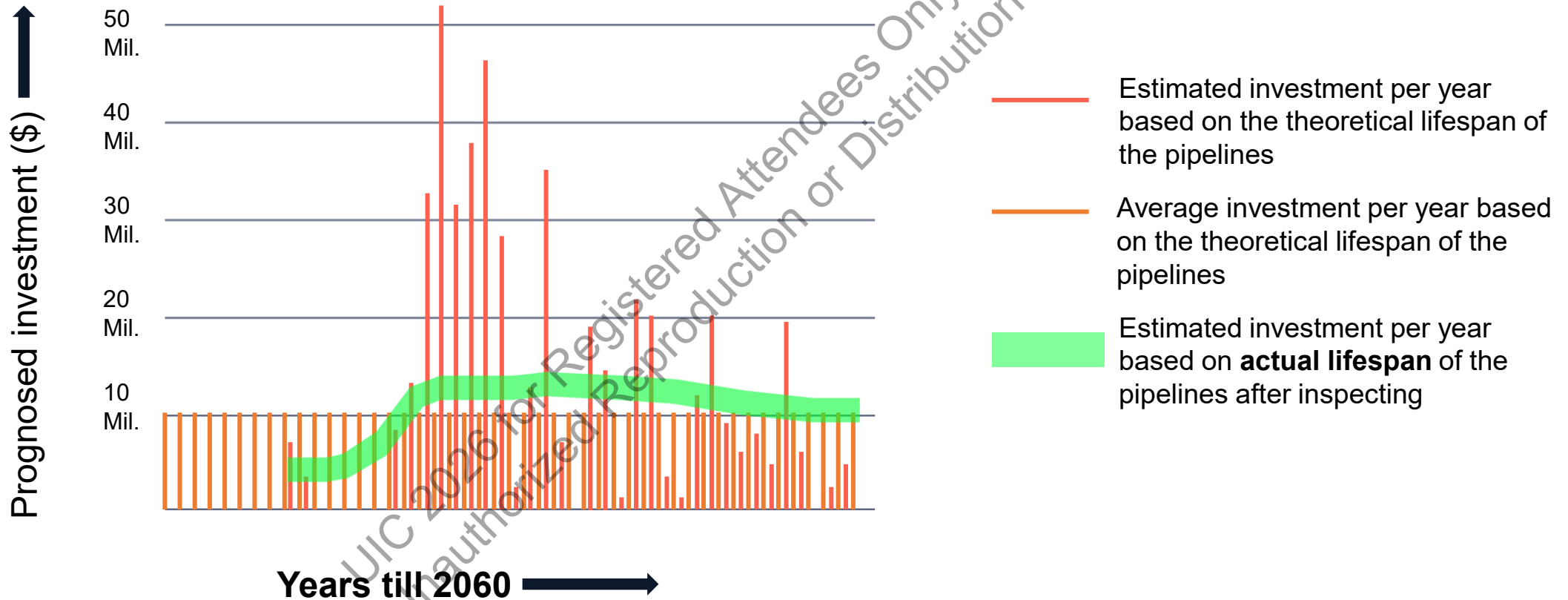

January 27 – 28, 2026

Henry B. Gonzalez Convention Center, San Antonio, Texas



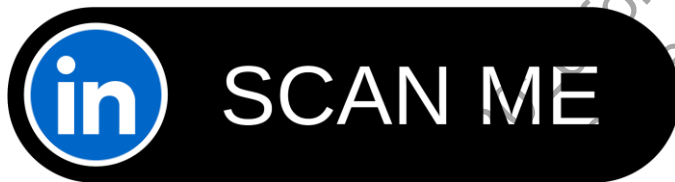

Unauthorized Reproduction or Distribution Prohibited
Unauthenticated Registered Attendees Only

Edzer Kooistra

edzer@acquaint.eu

+31 657480210

January 27 – 28, 2026

Henry B. Gonzalez Convention Center, San Antonio, Texas

