

Optimized Manhole Replacement

Matt Stiller
RimRiser

Taylor Scott
TMS Asphalt Specialties

Matt Kinson
Da-Lee Pavement Products



UIC 2026 for Registered Attendees Only
Unauthorized Reproduction or Distribution Prohibited

January 27 – 28, 2026

Henry B. Gonzalez Convention Center, San Antonio, Texas



Optimized Manhole Replacement

- Challenges with traditional methods
- Benefits of innovative alternative methods & materials
 - Bolt grade adjustments systems
 - Engineered concrete and asphalt replacement products
- Case Studies/Example Projects

UIC 2026 for Registered Attendees Only
Unauthorized Reproduction or Distribution Prohibited

January 27 – 28, 2026

Henry B. Gonzalez Convention Center, San Antonio, Texas



RimRiser - Bolt Grade Adjustment Systems



January 27 – 28, 2026

Henry B. Gonzalez Convention Center, San Antonio, Texas



RimRiser - Bolt Grade Adjustment Systems

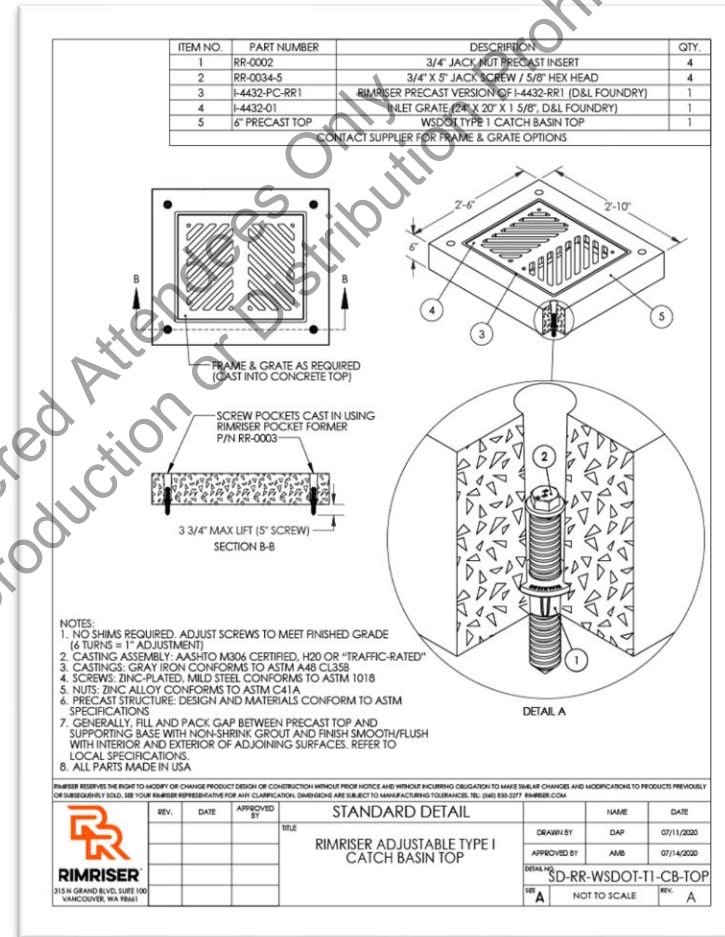
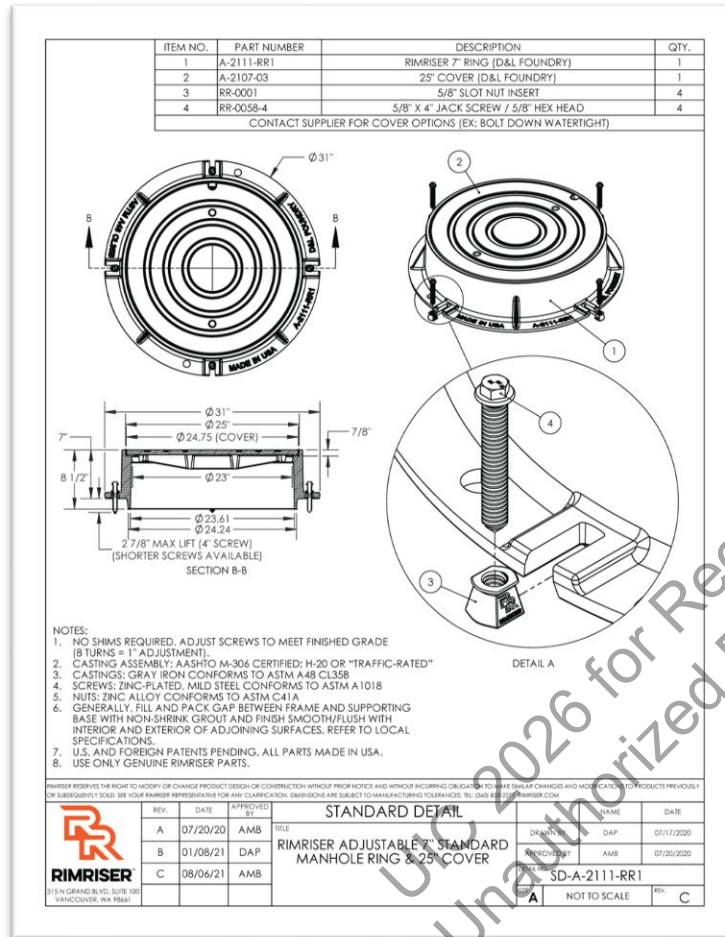

January 27 – 28, 2026

Henry B. Gonzalez Convention Center, San Antonio, Texas



RimRiser - Bolt Grade Adjustment Systems



January 27 – 28, 2026

Henry B. Gonzalez Convention Center, San Antonio, Texas



Manhole Repair System



- Quick Trafficability
- High Tensile and Flexural Strength
- No Settlement Issues
- Year-Round Usability
- No Need for Hot Repairs
- Single Supplier Advantage

January 27 – 28, 2026

Henry B. Gonzalez Convention Center, San Antonio, Texas



The cost of failed manholes

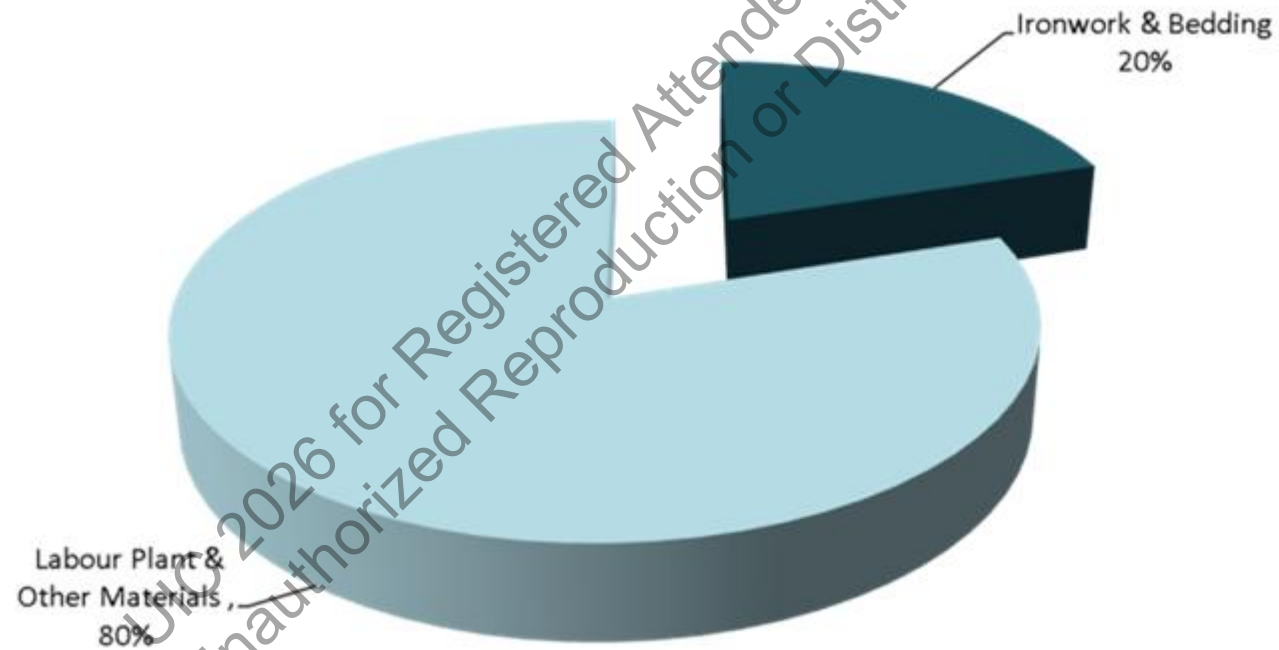

January 27 – 28, 2026

Henry B. Gonzalez Convention Center, San Antonio, Texas



Mortar Buoy

- Creates an instant form within the chamber
- Aids in the prevention of water infiltration
- Prevents concrete, mortar and debris falling into chamber
- Provides seamless finish to the inside of the chamber
- Environmentally friendly – can be re-used



January 27 – 28, 2026

Henry B. Gonzalez Convention Center, San Antonio, Texas



QC10 F

Flowable Rapid Strength Concrete

A fibre modified concrete for backfilling around manhole frames and catch basins



- Workability: 5 – 10 minutes
- Set time: 10 – 20 minutes
- 3000psi compressive strength after 60 minutes
 - Shrinkage compensated
 - Fibre modified
 - Rapid set
- Open to traffic within 60 minutes
 - Temp range 0-100f

January 27 – 28, 2026

Henry B. Gonzalez Convention Center, San Antonio, Texas



Mortar Buoy



January 27 – 28, 2026

Henry B. Gonzalez Convention Center, San Antonio, Texas



Mortar Buoy

Preventing water infiltration



QC10 F

Flowable Rapid Strength Concrete



January 27 – 28, 2026

Henry B. Gonzalez Convention Center, San Antonio, Texas



SCJ

Seal and Tack Coat Spray

A cold joint sealer applied onto vertical edges and surface base before applying asphalt.



UIC 2026
Unauthorized Reproduction Prohibited



Permanent Road Repair

Permanent Cold Lay Asphalt

- No waste
- Suitable for planned & reactive repairs
- Used in ALL weathers
- Permanent repair with SCJ Seal & Tack Spray
- Depth: 5 - 50mm
- Resealable pails
- Instantly trafficable



January 27 – 28, 2026

Henry B. Gonzalez Convention Center, San Antonio, Texas



Case Study- Sandy, OR



UIC 2025 for Registered Attendees Only
Unauthorized Reproduction or Distribution Prohibited

January 27 – 28, 2026

Henry B. Gonzalez Convention Center, San Antonio, Texas



Case Study- Sandy, OR



January 27 – 28, 2026

Henry B. Gonzalez Convention Center, San Antonio, Texas



Case Study- Pierce County, WA



January 27 – 28, 2026

Henry B. Gonzalez Convention Center, San Antonio, Texas



Thank you

Matt Stiller
RimRiser

matt.stiller@rimriser.com

Taylor Scott
TMS Asphalt Specialties

tscott@tmsasphaltspecialties.com

Matt Kinson
Da-Lee Pavement Products

matt@daleegroup.com

UIC 2026 for Registered Attendees Only
Unauthorized Reproduction or Distribution Prohibited

January 27 – 28, 2026

Henry B. Gonzalez Convention Center, San Antonio, Texas

